



**Pro-Shore, LLC**

Add: 2570 Boeing Way, Stockton, CA 95206

Tel: (209)636-2770

E-mail: [info@pro-shore.net](mailto:info@pro-shore.net)

Web: [www.pro-shore.com](http://www.pro-shore.com)

[www.pro-shore.com](http://www.pro-shore.com)



**Factory #1** (80,000m<sup>2</sup> Area)



**Factory #2** (100,000m<sup>2</sup> Area)

## CONTENTS

Pro-Shore System .....	01
Pro-Deck System .....	07
Pro-Net System .....	13
Pro-Span .....	17
Steel Ring Lock System .....	19
20K Heavy Duty Steel Shoring Frame System .....	23
10K Aluminum Shoring Frame System .....	25
Steel Frame Scaffolding System .....	27
Folding Scaffold .....	31
Scaffolding Plank .....	37

## Pro-Shore System

Pro-Shore System is new light weight soffit formwork specially designed for a pure concept ---SIMPLICITY.

Its unique modular structure enables easy assembly, easy transportation, easy storage and maintenance.

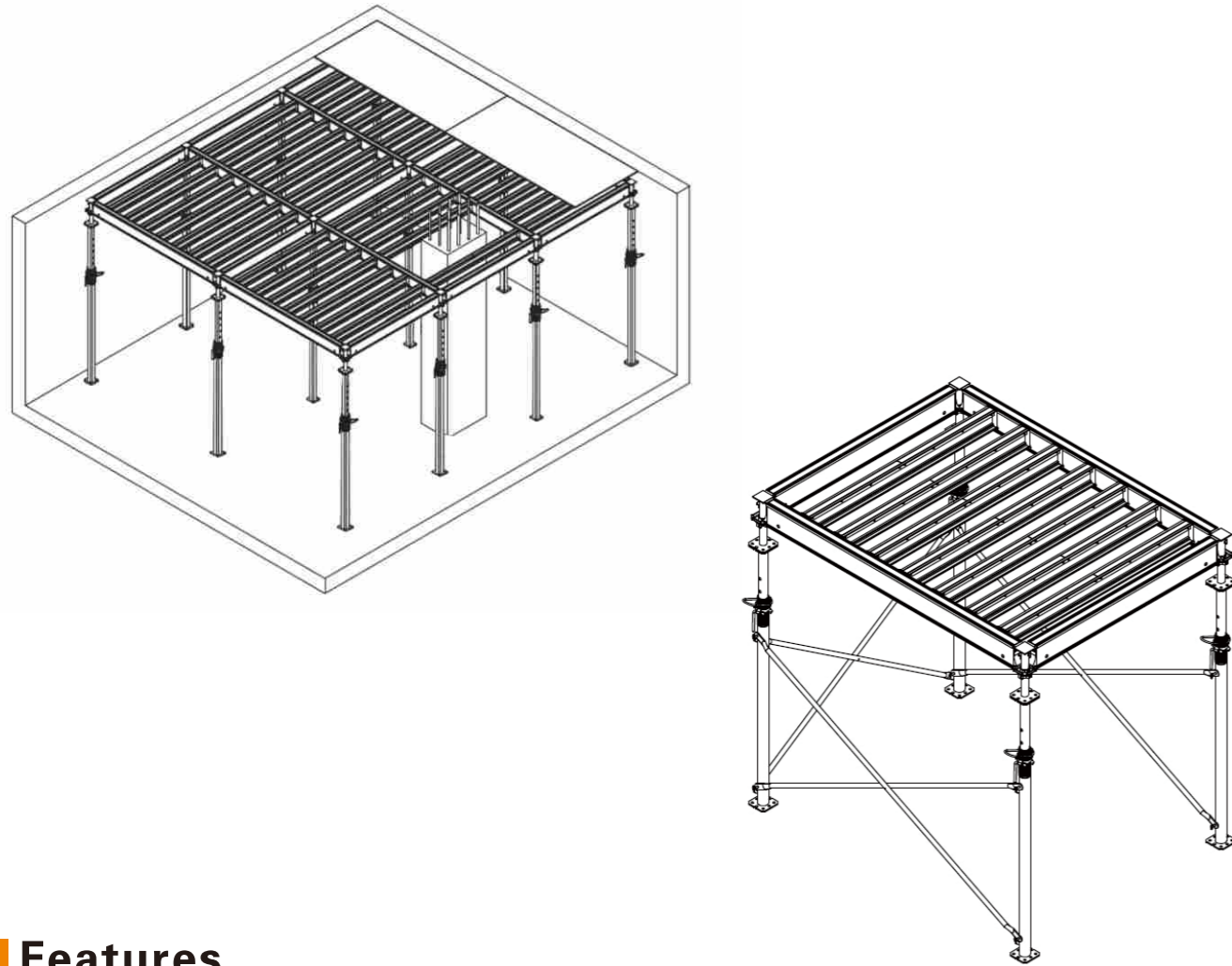

## Features

- Modular design makes for fast erection and dismantling, reducing labor cost while enhancing construction efficiency.
- Light weight panel configuration enables easy handling by a single worker.
- Universal Drophead not only ensures tight and firm locking to panel corners but also permits easy stripping of horizontal members including panels and ledgers so that they can be cycled to next floor.
- HD finish reduces the adhesion of fresh concrete to the least, minimizing cleaning and maintenance cost.

Modular design and various specifications make Pro-Shore System a simple and versatile soffit formwork system, suitable for ranges of concrete slabs



Adjustable prop and universal drophead are used for panels erection and dismantling. The universal drophead unit connects to the prop and allows Ledgers and LVL to be removed while one concrete pour is done, leaving the prop and universal drophead in place alone to be used as a Re-Shore until the concrete reaches sufficient strength.

## Components

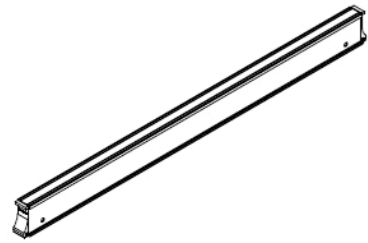

Description	Weight(lbs)
6' Ledger	41
8' Ledger	54
10' Ledger	67

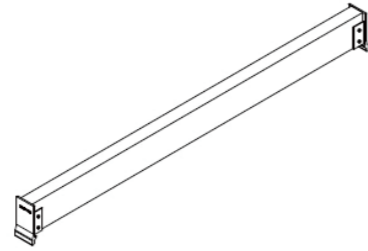

Description	Weight(lbs)
4' LVL Joist	15
5' LVL Joist	18
6' LVL Joist	21

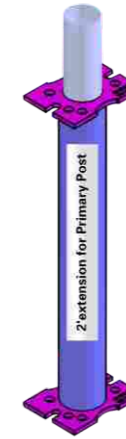

Description	Weight(lbs)
2' Extension For Primary Post	15

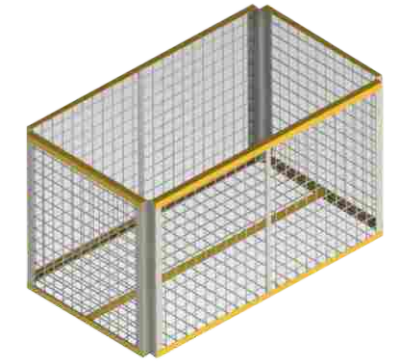

Description	Weight(lbs)
Storage Basket	73

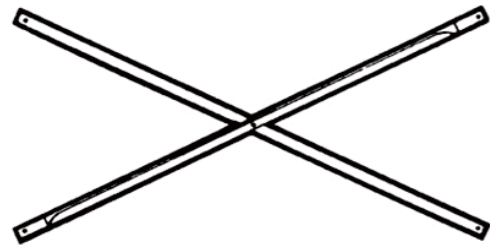

Description	Weight(lbs)
4' x 4' Crossbrace	9
4' x 5' Crossbrace	10
4' x 6' Crossbrace	11
4' x 8' Crossbrace	13
4' x 10' Crossbrace	14

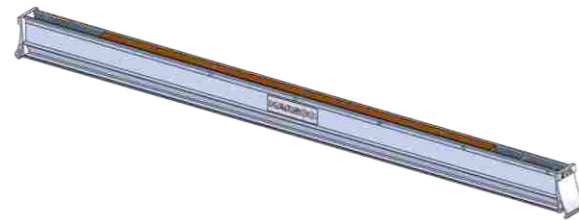

Description	Weight(lbs)
6' Aluminum Joist	21

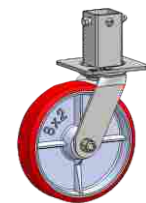

Swivel Casters

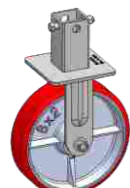

Fixed Casters

Description	Weight(lbs)
Swivel Casters	14
Fixed Casters	9

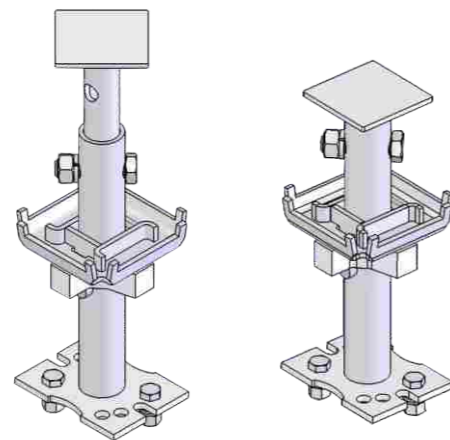

Description	Weight(lbs)
Universal Drophead	17

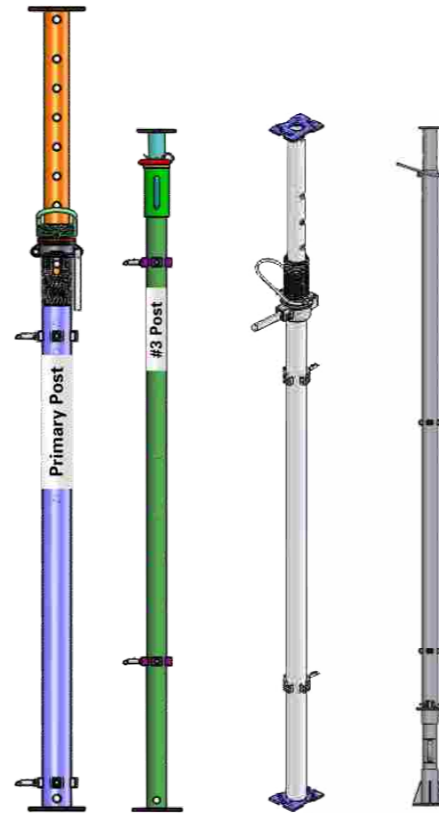

Description	Weight(lbs)
Primary Post	58
#3 Post	41
#5 Post	91.96
PS Post	84.7

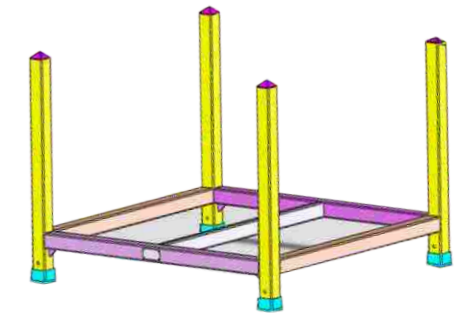

Standard storage rack

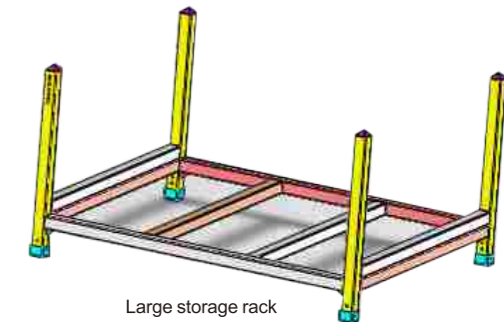

Large storage rack

Description	Weight(lbs)
Standard Storage Rack	100
Large Storage Rack	113

**Components**

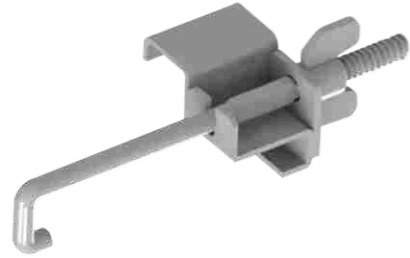

Description	Weight(lbs)
Panel Safety Clip	0.9



Description	Weight(lbs)
Ledger to Ledger Clip	0.5

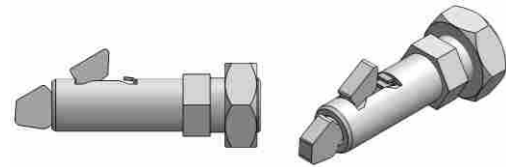

Description	Weight(lbs)
Jetlok	0.1



Description	Weight(lbs)
Ledger to Drophead Clip	0.5



Description	Weight(lbs)
Plastic Spud	0.1



Description	Weight(lbs)
Ledger Hold Down Clip	0.9



Description	Weight(lbs)
Bracing Slider w/ 2 Jetloks	5.7

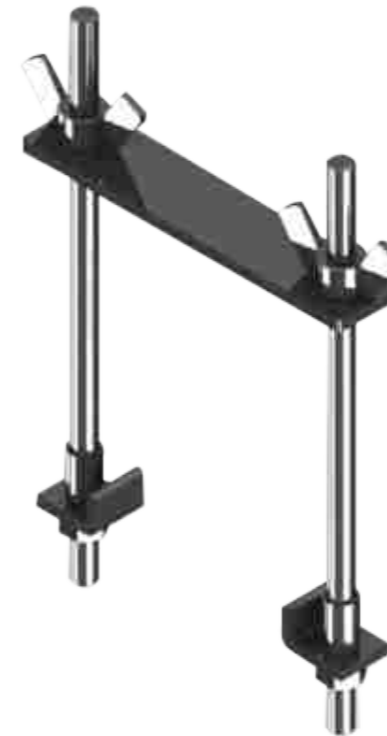

Description	Weight(lbs)
Ledger Hanger	10

Description	Weight(lbs)
Panel Cart	110

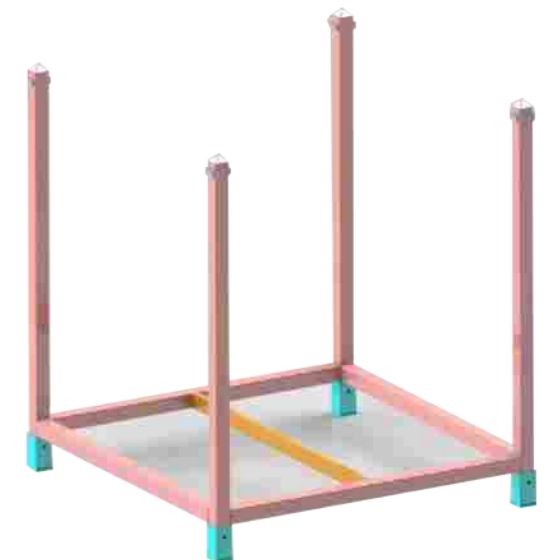

## Pro-Deck System

Pro-Deck System is new light weight soffit formwork specially designed for a pure concept ---SIMPLICITY.

Its unique modular structure enables easy assembly, easy transportation, easy storage and maintenance.

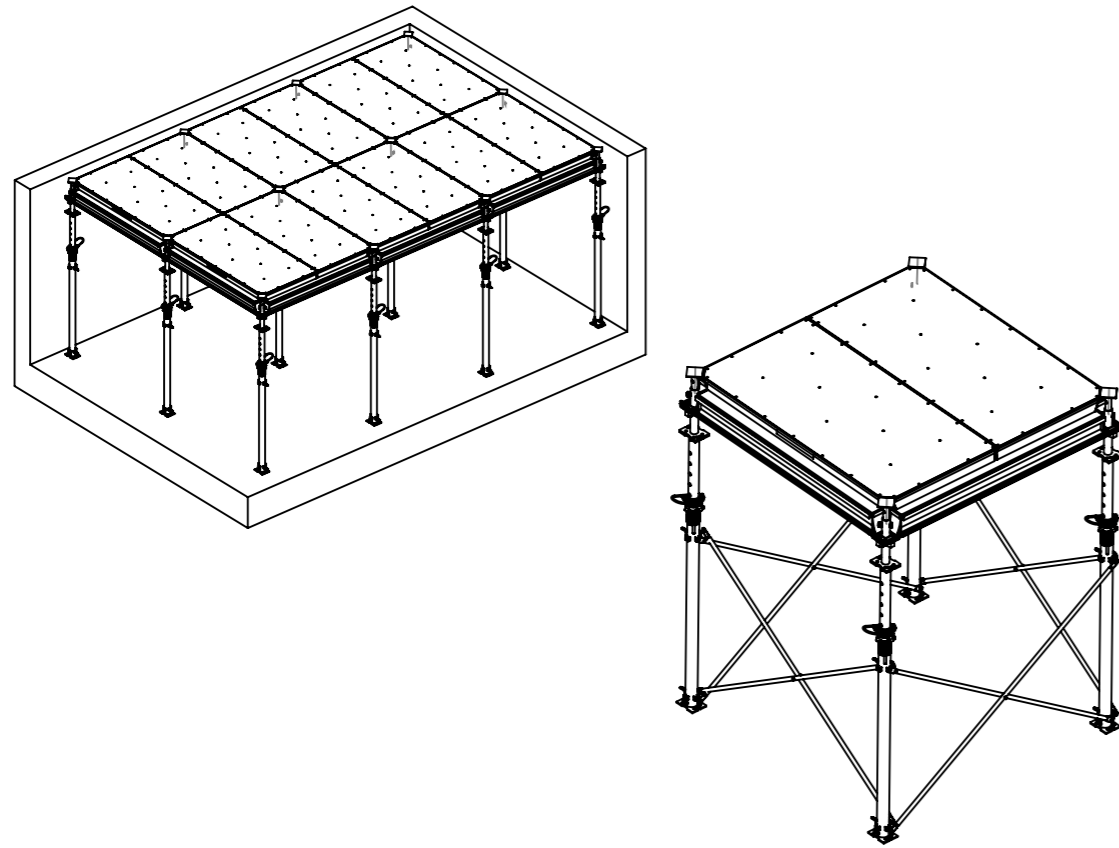

## Features

- Modular design makes for fast erection and dismantling, reducing labor cost while enhancing construction efficiency.
- Light weight panel configuration enables easy handling by a single worker.
- Universal Drophead not only ensures tight and firm locking to panel corners but also permits easy stripping of horizontal members including panels and ledgers so that they can be cycled to next floor.
- HD finish reduces the adhesion of fresh concrete to the least, minimizing cleaning and maintenance cost.
- Various options: Pro-Deck panel or loose plywood for decking options.

Modular design and various specifications make Pro-Deck System a simple and versatile soffit formwork system, suitable for ranges of concrete slabs



Light weight aluminum panels and adjustable props lead to less labor and higher job efficiency



Adjustable prop and universal drophead are used for panels erection and dismantling. The universal drophead unit connects to the prop and allows Panels and Ledgers to be removed while one concrete pour is done, leaving the prop and universal drophead in place alone to be used as a Re-Shore until the concrete reaches sufficient strength.

## Components

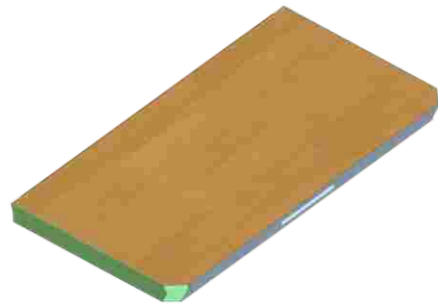

Description	Weight(lbs)
6'x3' Pro-Deck Panel	58

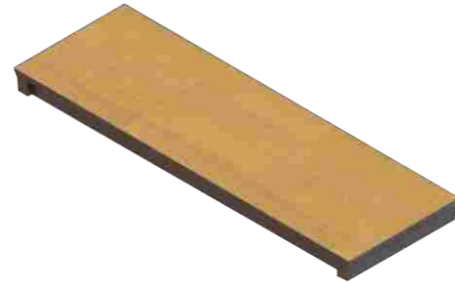

Description	Weight(lbs)
6'x2' Pro-Deck Panel	45

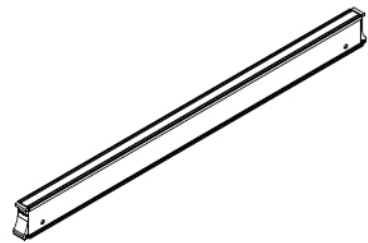

Description	Weight(lbs)
6' Ledger	41
8' Ledger	54
10' Ledger	67

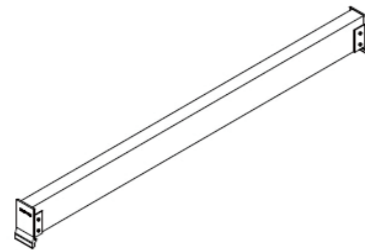

Description	Weight(lbs)
4' LVL Joist	15
5' LVL Joist	18
6' LVL Joist	21

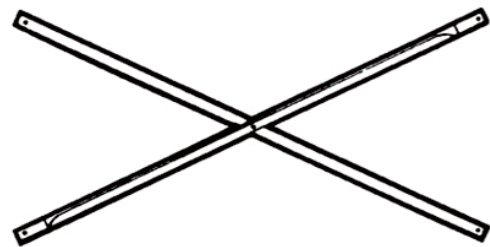

Description	Weight(lbs)
4' x 4' Crossbrace	9
4' x 5' Crossbrace	10
4' x 6' Crossbrace	11
4' x 8' Crossbrace	13
4' x 10' Crossbrace	14

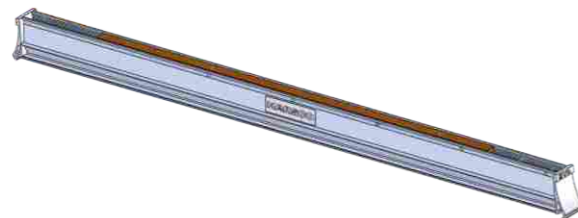

Description	Weight(lbs)
6' Aluminum Joist	21

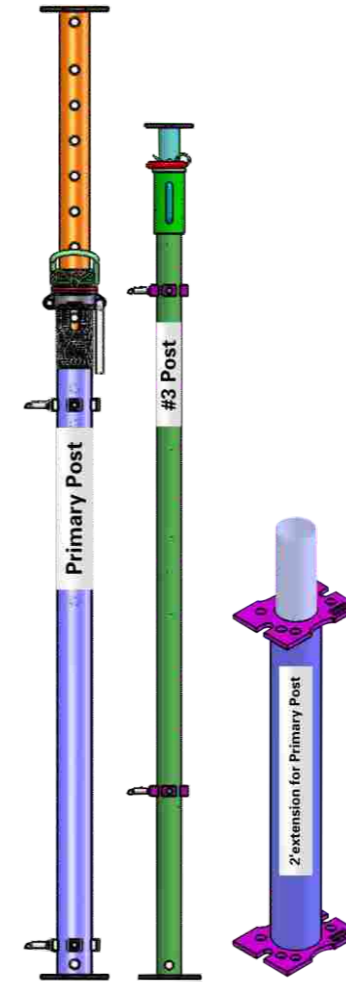

Description	Weight(lbs)
Primary Post	58
#3 Post	41
2' Extension For Primary Post	15

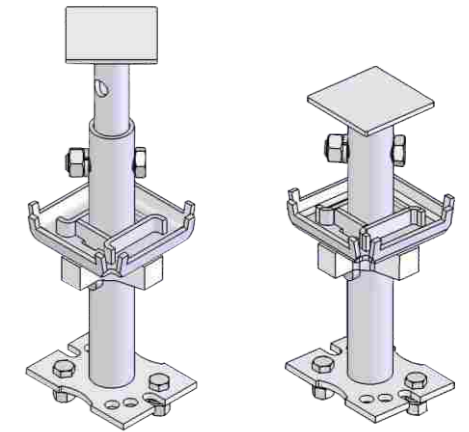

Description	Weight(lbs)
Universal Drophead	17

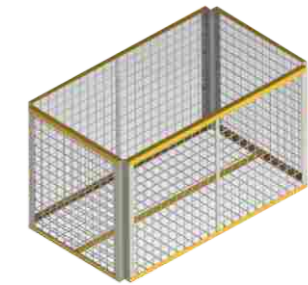

Description	Weight(lbs)
Storage Basket	73

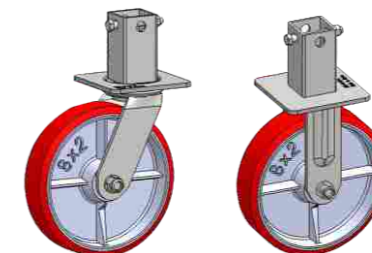

Swivel Casters      Fixed Casters

Description	Weight(lbs)
Swivel Casters	14
Fixed Casters	9

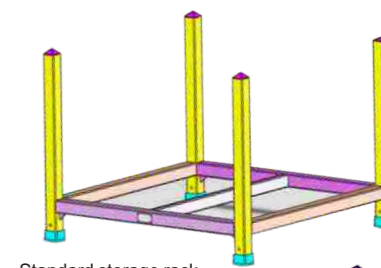

Standard storage rack

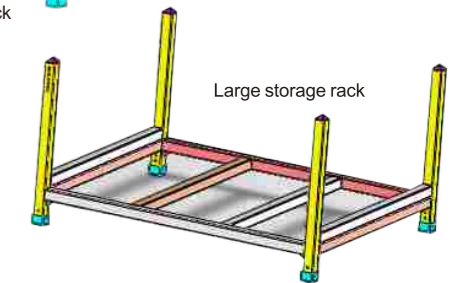

Large storage rack

Description	Weight(lbs)
Standard Storage Rack	100
Large Storage Rack	113

## Components

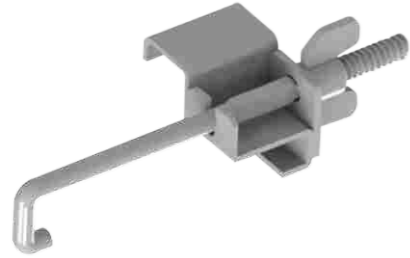

Description	Weight(lbs)
Panel Safety Clip	0.9



Description	Weight(lbs)
Ledger to Ledger Clip	0.5

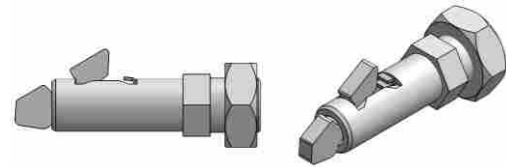

Description	Weight(lbs)
Jetlok	0.1



Description	Weight(lbs)
Ledger to Drophead Clip	0.5



Description	Weight(lbs)
Plastic Spud	0.1



Description	Weight(lbs)
Ledger Hold Down Clip	0.9



Description	Weight(lbs)
Bracing Slider w/ 2 Jetloks	5.7

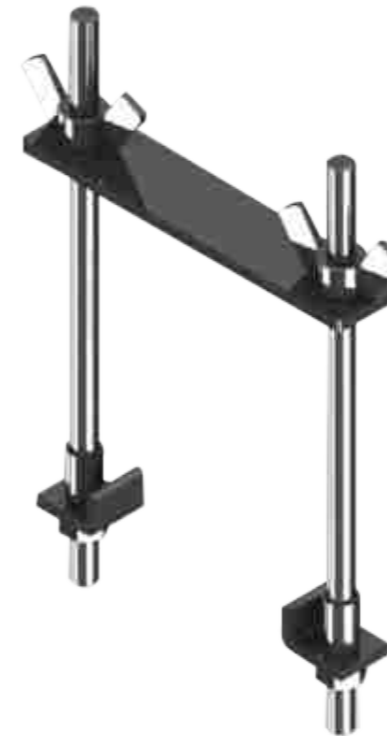

Description	Weight(lbs)
Ledger Hanger	10

Description	Weight(lbs)
Panel Cart	110

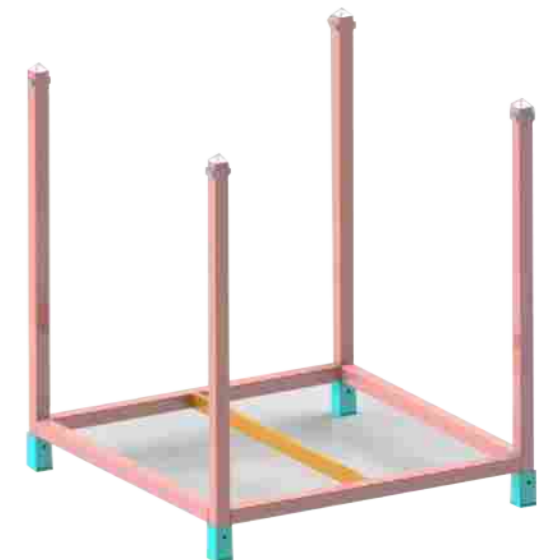



## Pro-Net System

Pro-Shore's revolutionary Pro-Net System alleviates the need for Fall Protection and costly Man Hours by providing an ALL Aluminum Lightweight Self Climbing Structure that easily affixes temporarily to all various types Deck Edge of the Concrete Slab Structures. The Self Climbing Lightweight Aluminum Frame is then hoisted up the Structure 3 floors at a time by use of either Tower Crane or time saving Mechanical Winches. Use of Winches cuts down on costly Tower Crane Time and they allow you to lift the Safety Debris Netting System either per Bay, per side of the Building, or all sides of the building (qty of Winches dictates) simultaneously as the Building goes up.



Pro-Net System stays attached to the structure throughout Construction until you top out; therefore there are no costly and dangerous man-hours necessary to breakdown and bring the Safety Netting Structure back inside the building and up the man-lift or stairs each time you want to jump the Safety Debris Net. (This equates to over \$100,000 in labor savings alone on a typical 40+ Story high-rise Building in California)



Pro-Net System easily adapts to balconies, soffits and corners and it accepts standard off-the-shelf Mesh Netting from any supplier and can be easily attached to the Safety Netting Structure with use of standard clips/carabiners.

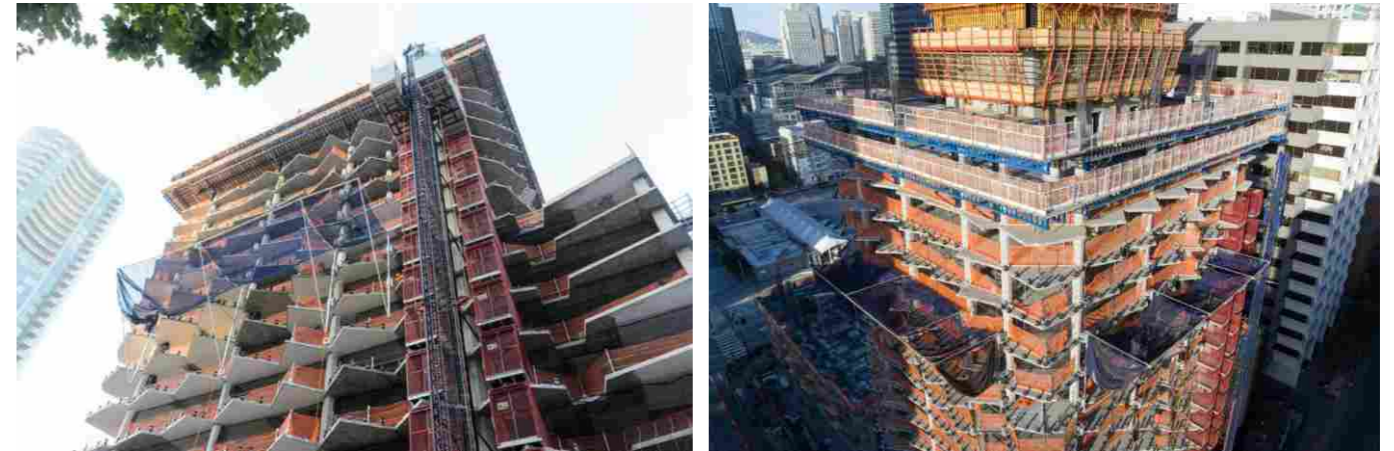

For more information on Pro-Net System, please visit our website at [www.pro-shore.com](http://www.pro-shore.com)



## Components

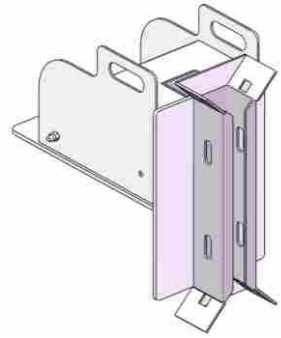

Description	Weight(lbs)
Mounting Bracket Assy	73.5

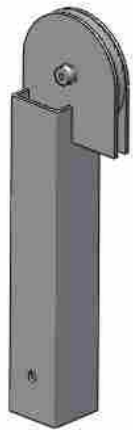

Description	Weight(lbs)
Removing Sheave Assembly	12.3

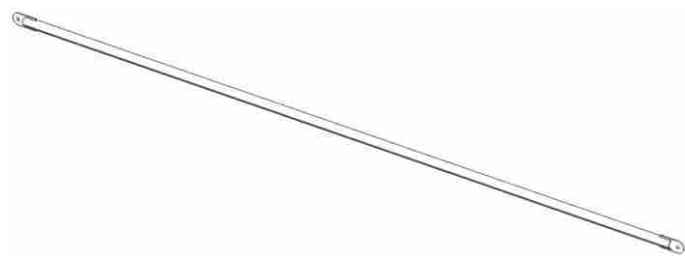

Description	Weight(lbs)
Main Beam Assembly	112.4



Description	Weight(lbs)
Lower Connecting Pipe Assembly	12.3

Description	Weight(lbs)
Upper Connecting Pipe Assembly	21.3



Description	Weight(lbs)
Outrigger Assembly	39.8



Description	Weight(lbs)
Outside Tube	60

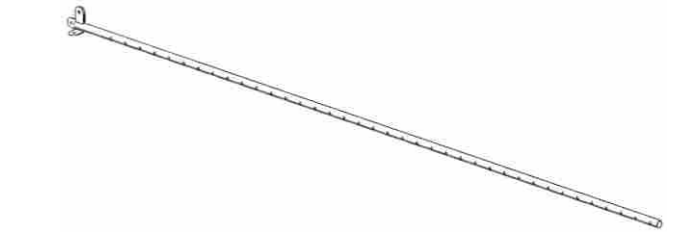
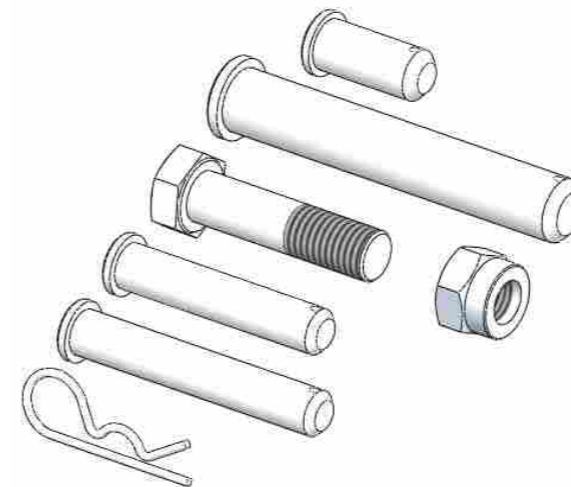

Description	Weight(lbs)
Inner Telescoping Bracket	27



Description	Weight(lbs)
Inside Tube Assy	27.7

Description	Weight(lbs)
3/4" Dia, 2" Long Pin With Clevis Pin And Tapered End	0.27
1" Dia, 6" Long Pin With Clevis Pin And Tapered End	1.34
High-Strength Steel Cap Screw	0.62
Grade 8 Steel Nylon-Insert Hex Locknut	0.20
18x90mm Long Pin With Clevis Pin	0.42
18x110mm Long Pin With Clevis Pin	0.51
R Pin	0.02

## Pro-Span

Pro-Span is the most advanced and economical concrete form support for spans up to 17'4". It can be used alone on jobs where long spans are needed, or together with standard beams and other quick beams on jobs where longer spans are required. In either case, it reduces shoring costs



## Pro-Span (QuickBeamIII) Design Guidelines

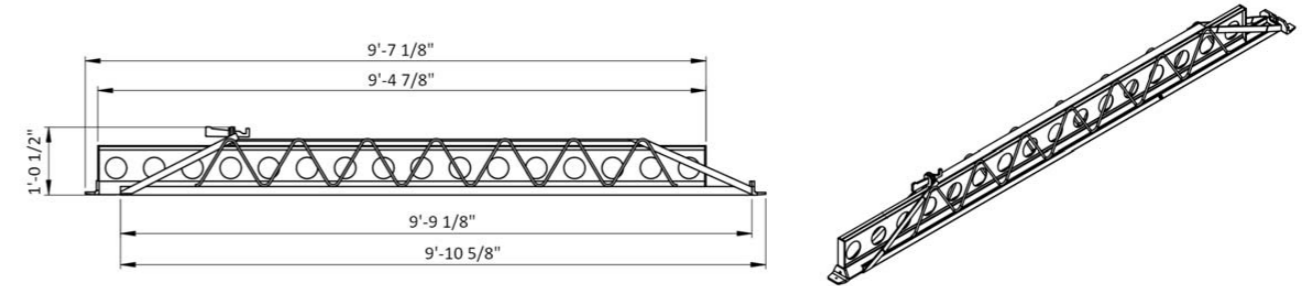

QB III	Length 9'-11"....17'-4"	Weight, lbs 117	Max End Reaction, lbs 2860	Max Bending Moment, lb-ft 8680								
Slab Thickness	Actual Load, lbs/ft <sup>2</sup>	Max span for a spacing:										
		8"	12"	16"	19.2"	24"	28"	30"	32"	36"	40"	42"
72	72	17'-4"	17'-4"	17'-4"	17'-4"	17'-4"	17'-4"	17'-4"	17'-4"	17'-4"	17'-0"	16'-6"
78	78	17'-4"	17'-4"	17'-4"	17'-4"	17'-4"	17'-4"	17'-4"	17'-4"	17'-2"	16'-5"	15'-11"
85	85	17'-4"	17'-4"	17'-4"	17'-4"	17'-4"	17'-4"	17'-4"	17'-3"	16'-5"	15'-8"	15'-4"
91	91	17'-4"	17'-4"	17'-4"	17'-4"	17'-4"	17'-4"	17'-4"	16'-10"	15'-10"	15'-1"	14'-10"
97	97	17'-4"	17'-4"	17'-4"	17'-4"	17'-4"	17'-4"	16'-10"	16'-4"	15'-4"	14'-8"	14'-4"
103	103	17'-4"	17'-4"	17'-4"	17'-4"	17'-4"	17'-0"	16'-5"	15'-11"	14'-11"	14'-2"	13'-10"
110	110	17'-4"	17'-4"	17'-4"	17'-4"	17'-4"	16'-3"	15'-11"	15'-5"	14'-6"	13'-10"	13'-5"
116	116	17'-4"	17'-4"	17'-4"	17'-4"	17'-4"	16'-0"	15'-4"	14'-11"	14'-0"	13'-5"	13'-1"
122	122	17'-4"	17'-4"	17'-4"	17'-4"	16'-10"	15'-7"	15'-0"	14'-5"	13'-9"	13'-0"	12'-9"
128	128	17'-4"	17'-4"	17'-4"	17'-4"	16'-5"	15'-3"	14'-9"	14'-3"	13'-4"	12'-9"	12'-5"
135	135	17'-4"	17'-4"	17'-4"	17'-4"	16'-0"	14'-10"	14'-4"	13'-10"	13'-0"	12'-5"	12'-1"
141	141	17'-4"	17'-4"	17'-4"	17'-4"	15'-8"	14'-7"	14'-0"	13'-6"	12'-9"	12'-2"	11'-6"
147	147	17'-4"	17'-4"	17'-4"	17'-3"	15'-5"	14'-3"	13'-9"	13'-4"	12'-6"	11'-10"	11'-2"
153	153	17'-4"	17'-4"	17'-4"	16'-11"	15'-2"	14'-1"	13'-5"	13'-0"	12'-3"	11'-3"	10'-8"
160	160	17'-4"	17'-4"	17'-4"	16'-7"	14'-10"	13'-8"	13'-2"	12'-10"	11'-11"	10'-8"	10'-2"
166	166	17'-4"	17'-4"	17'-4"	16'-1"	14'-5"	13'-5"	12'-11"	12'-7"	11'-6"	10'-4"	9'-10"
172	172	17'-4"	17'-4"	17'-4"	15'-11"	14'-2"	13'-2"	12'-9"	12'-4"	11'-1"	9'-10"	9'-6"
178	178	17'-4"	17'-4"	17'-2"	15'-8"	14'-0"	12'-11"	12'-6"	12'-4"	10'-8"	9'-7"	-
184	184	17'-4"	17'-4"	16'-10"	15'-5"	13'-10"	12'-9"	12'-4"	12'-1"	10'-4"	-	-
191	191	17'-4"	17'-4"	16'-5"	15'-2"	13'-6"	12'-7"	11'-10"	11'-1"	10'-0"	-	-
197	197	17'-4"	17'-4"	16'-3"	14'-11"	13'-4"	12'-4"	11'-7"	10'-8"	-	-	-
203	203	17'-4"	17'-4"	16'-0"	14'-8"	13'-1"	12'-2"	11'-3"	10'-4"	-	-	-
209	209	17'-4"	17'-4"	15'-10"	14'-5"	12'-11"	11'-9"	10'-11"	10'-0"	-	-	-
216	216	17'-4"	17'-4"	15'-7"	14'-3"	12'-8"	11'-4"	10'-7"	-	-	-	-
222	222	17'-4"	17'-4"	15'-4"	14'-1"	12'-6"	11'-0"	10'-4"	-	-	-	-
228	228	17'-4"	17'-4"	15'-1"	13'-11"	12'-4"	10'-9"	10'-0"	-	-	-	-
234	234	17'-4"	17'-4"	14'-11"	13'-8"	12'-2"	10'-6"	9'-9"	-	-	-	-
241	241	17'-4"	16'-11"	14'-8"	13'-6"	11'-10"	10'-2"	9'-6"	-	-	-	-
253	253	17'-4"	16'-5"	14'-4"	13'-2"	11'-1"	9'-8"	-	-	-	-	-
266	266	17'-4"	16'-1"	14'-0"	12'-11"	10'-10"	-	-	-	-	-	-
278	278	17'-4"	15'-10"	13'-8"	12'-7"	10'-4"	-	-	-	-	-	-
291	291	17'-4"	15'-5"	13'-4"	12'-4"	9'-7"	-	-	-	-	-	-
303	303	17'-4"	15'-2"	13'-1"	11'-11"	-	-	-	-	-	-	-
316	316	17'-4"	14'-10"	12'-10"	11'-5"	-	-	-	-	-	-	-
328	328	17'-0"	14'-6"	12'-7"	10'-11"	-	-	-	-	-	-	-
341	341	16'-9"	14'-3"	12'-5"	10'-6"	-	-	-	-	-	-	-

## Steel Ring Lock System

Steel Ring Lock System is versatile high-strength galvanized steel modular scaffold which is built for increased strength, versatility and usability.

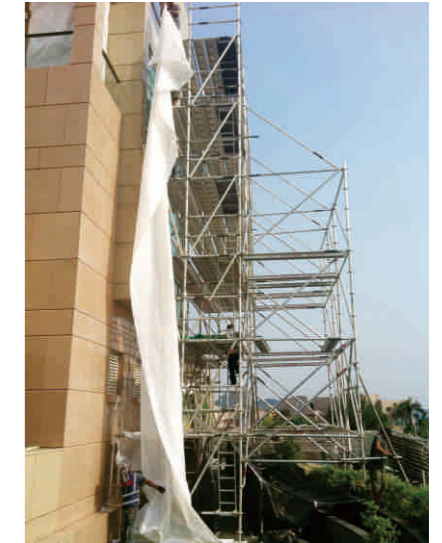
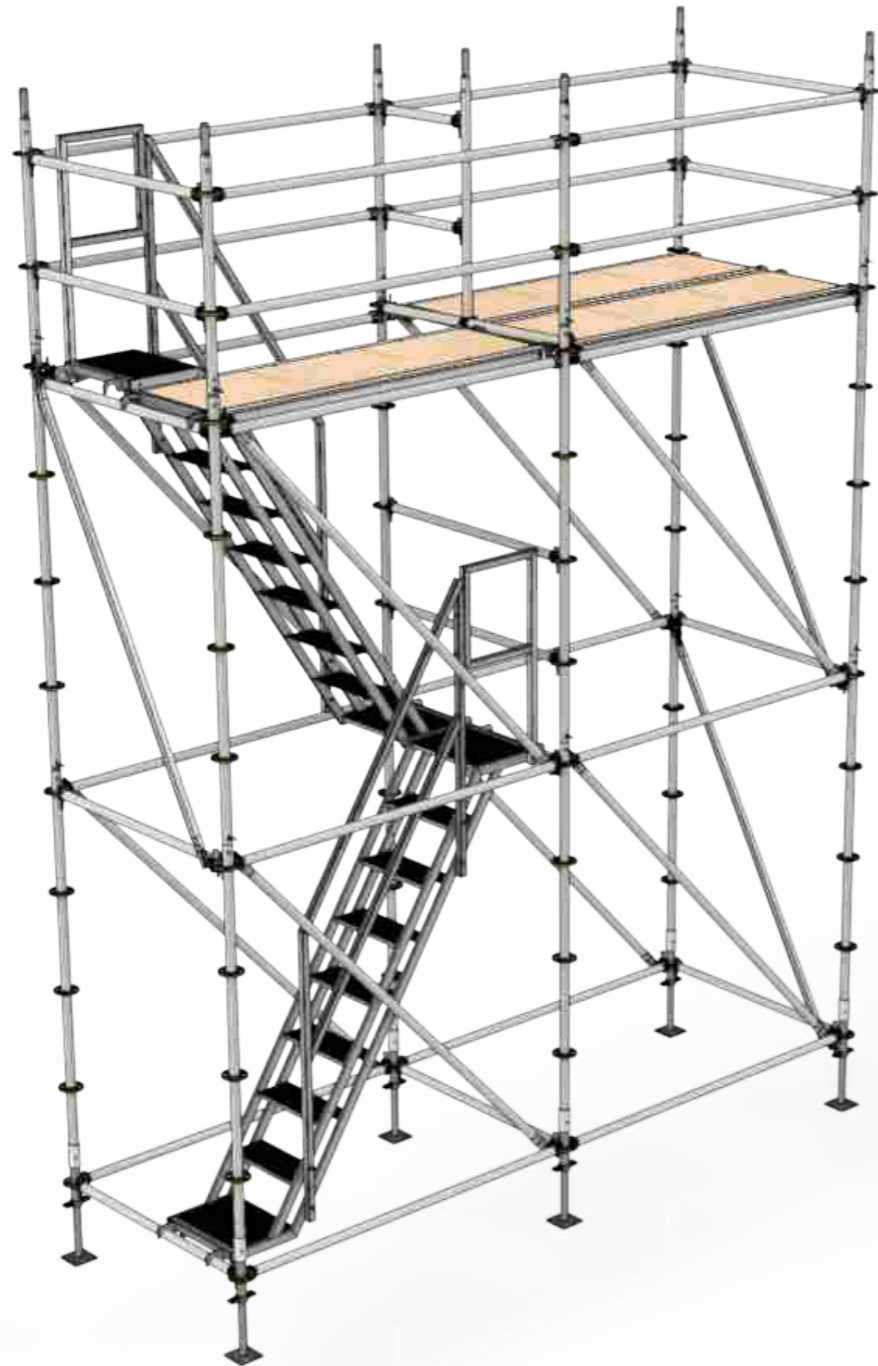

### Features & Benefits:

- **High Strength and Safety**

Steel Ring Lock System are built for high strength and safety, consisting of galvanized high-strength steel modular components.

- **Various Sizes for Different Jobs Requirement**

Horizontals, diagonals and verticals are available in a variety of lengths, ranging from 2ft to 10ft, which allows the system to be built in any configuration to suit different job requirement.

- **Versatility and Applications**

Steel Ring Lock System is a versatile scaffold which is applicable for all types of access and support structure such as building construction, external and internal wall maintenance, subways, tunnels, bridge.



## Components



Description	Size L	Material	Weight(lbs)
Standard Post	1'-7"	Q345	6.72
	3'-3"	Q345	11.93
	4'-11"	Q345	17.86
	6'-6"	Q345	22.16
	8'-2"	Q345	27.89
	9'-10"	Q345	31.81



Description	Size L	Material	Weight(lbs)
Horizontal Brace	2'	Q235	6.36
	3'	Q235	8.89
	4'	Q235	11.4
	5'	Q235	13.93
	6'	Q235	16.5
	7'	Q235	18.92
	8'	Q235	21.48
	10'	Q235	26.58



Description	Size L x H	Material	Weight(lbs)
Diagonal Brace	3'x6'-6"	Q235	20.40
	4'x6'-6"	Q235	21.37
	5'x6'-6"	Q235	22.58
	6'x6'-6"	Q235	24.12
	7'x6'-6"	Q235	25.52
	8'x6'-6"	Q235	27.26
	10'x6'-6"	Q235	30.98



Description	Size L	Material	Weight(lbs)
Steel Plank	3'	Q235	15.78
	4'	Q235	19.71
	5'	Q235	23.63
	6'	Q235	28.00
	7'	Q235	32.36
	8'	Q235	36.29
	10'	Q235	44.58



Description	Size L	Material	Weight(lbs)
Screw Jack	2'	Q235	10.36



Description	Size L	Material	Weight(lbs)
Base Collar	1'	Q345	5.15



Description	Size L x H	Material	Weight(lbs)
Steel Stair Case	7'x6'-6"	Q235	197.00



Description	Size L	Material	Weight(lbs)
Double Ledger	6'	Q235	26.52
	7'	Q235	30.51
	8'	Q235	36.38
	10'	Q235	45.59



Description	Size L x H	Material	Weight(lbs)
Large Trusses	16'x1'-7"	Q235	101.10

## 20K Heavy Duty Steel Shoring Frame System

Great Strength: Tested up to 20,000lbs(9,091kg) per frame.

Fast and Efficient: Modular structure with only 4 basic components enables easy and fast handling on the jobsite.

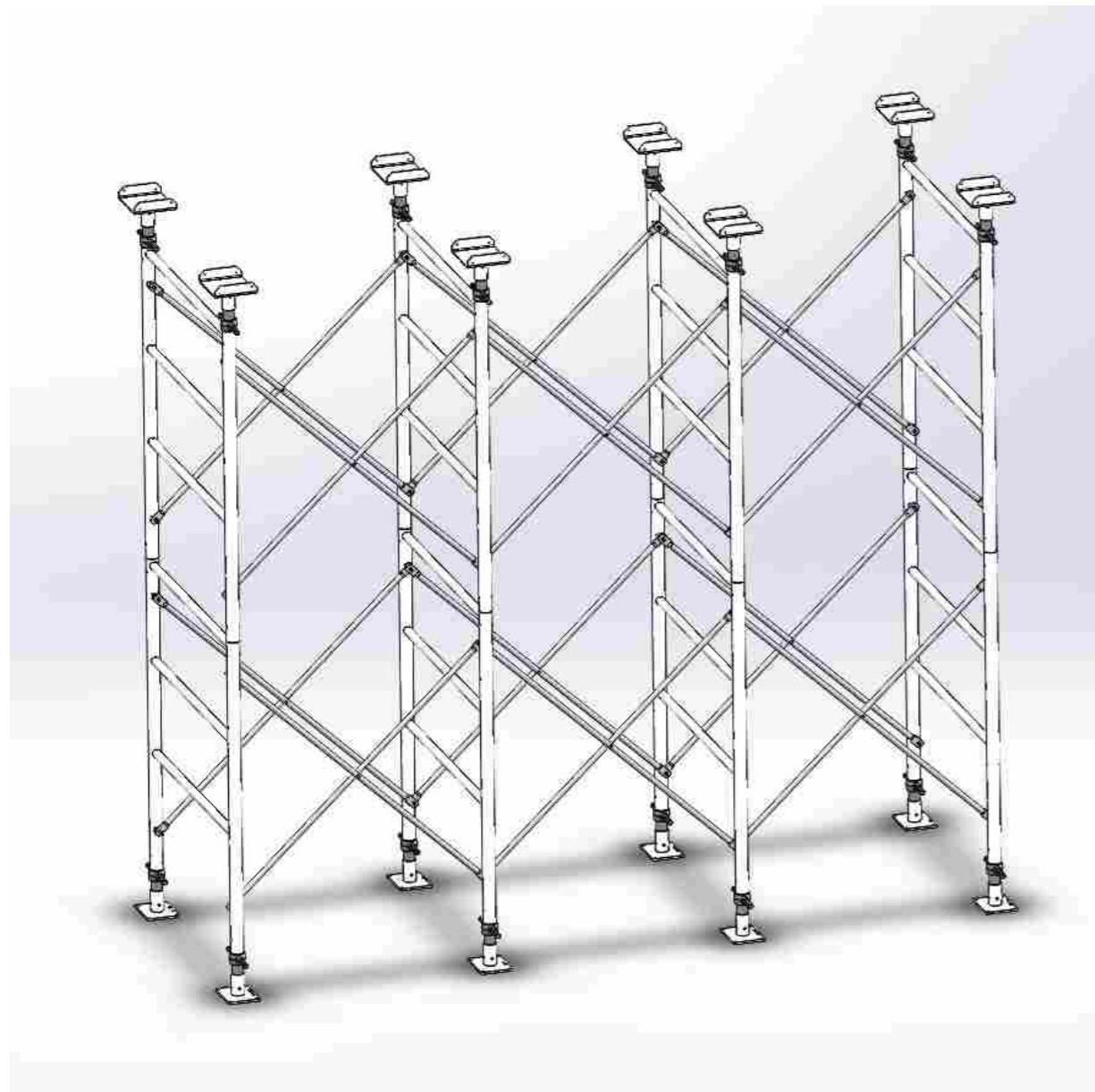

### Wide Applications

- Heavy duty falsework
- Bridges and Tunnels
- Commercial and Industrial Buildings

## Components



Description	Weight(lbs)
3'6"Hx2'W Frame	36.2
3'6"Hx4'W Frame	46.7



Description	Weight(lbs)
5'Hx2'W Frame	47
5'Hx4'W Frame	57.7



Description	Weight(lbs)
6'Hx2'W Frame	57.5
6'Hx4'W Frame	71.6

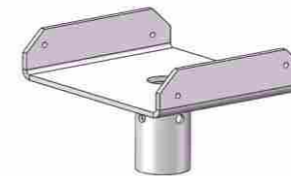

Description	Weight(lbs)
U Head	8.6

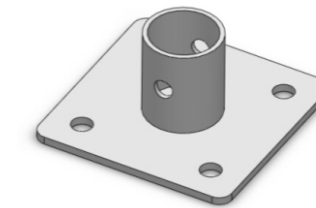

Description	Weight(lbs)
Base Plate	6.4

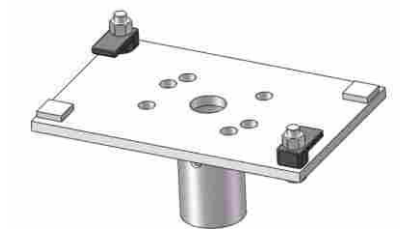

Description	Weight(lbs)
Top Head	10



Frame Spacing from 2'to 10', every size increment at 1'

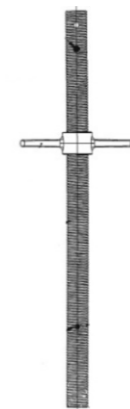

Description	Weight(lbs)
ADJ. Ext. Leg 12"	12.8
ADJ. Ext. Leg 24"	16.8

## 10K Aluminum Shoring Frame System

Light weight — Easy to be handled by a single worker.  
 Great Strength — Tested up to 10,000lbs(4,545kg) per frame.  
 Various sizes are available to meet your specific job requirements.

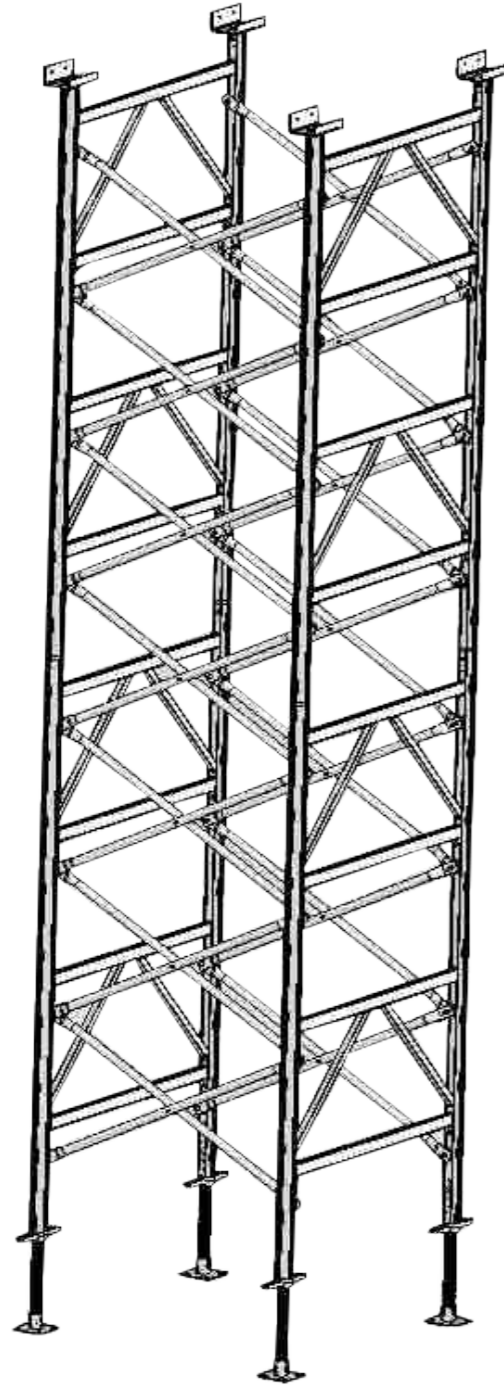

## Components

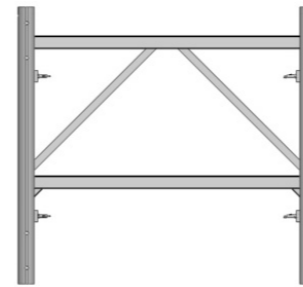

Description	Weight(lbs)
4'x4' Frame	23.1
5'x4' Frame	24.5
6'x4' Frame	26

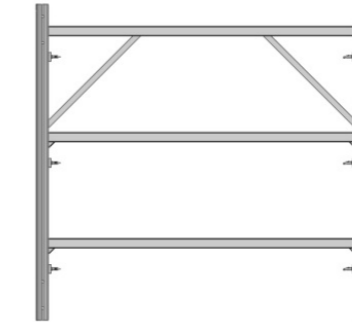

Description	Weight(lbs)
4'x6' Frame	33.9
5'x6' Frame	36.3
6'x6' Frame	38.3

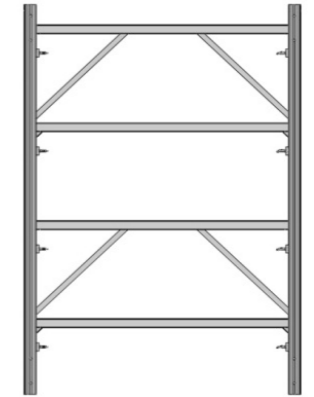

Description	Weight(lbs)
4'x8' Frame	46.9
5'x8' Frame	49.3
6'x8' Frame	52.6

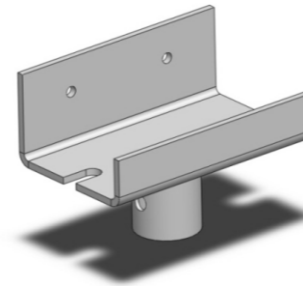

Description	Weight(lbs)
5'x8" U Head	5.5

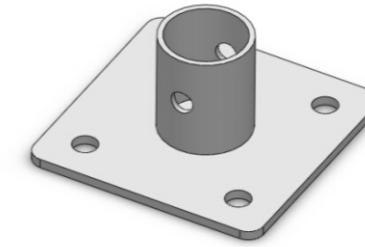

Description	Weight(lbs)
6'x6" Base Plate	2.9



Description	Weight(lbs)
Tr1.9'x2'-8" Aluminum Jack	7.7

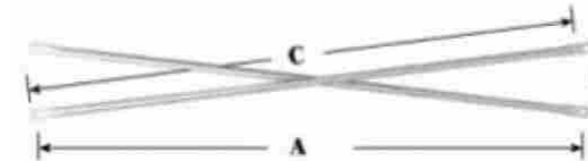

Description	A	B	C	Weight(kg)
4'x3' Cross Brace	4'	3'	5'	7.5
4'x4' Cross Brace	4'	4'	5.66'	8.4
5'x4' Cross Brace	5'	4'	6.4'	9.3
6'x4' Cross Brace	6'	4'	7.2'	10.6
7'x4' Cross Brace	7'	4'	8.06'	11.8
8'x4' Cross Brace	8'	4'	8.94'	13
10'x4' Cross Brace	10'	4'	10.77'	15.4

## Steel Frame Scaffolding System

Pro-Shore, a member of SIA (Scaffold Industry Association, USA), has been supplying steel frame system to North American and Brasil markets for 15 years. Its superior quality is well acknowledged by the markets and by the clients.



### Features

- Easy assembling and dismantling
- Fast erection
- High-strength steel tubing
- Safe, durable

### Various designs to meet your specific job requirements

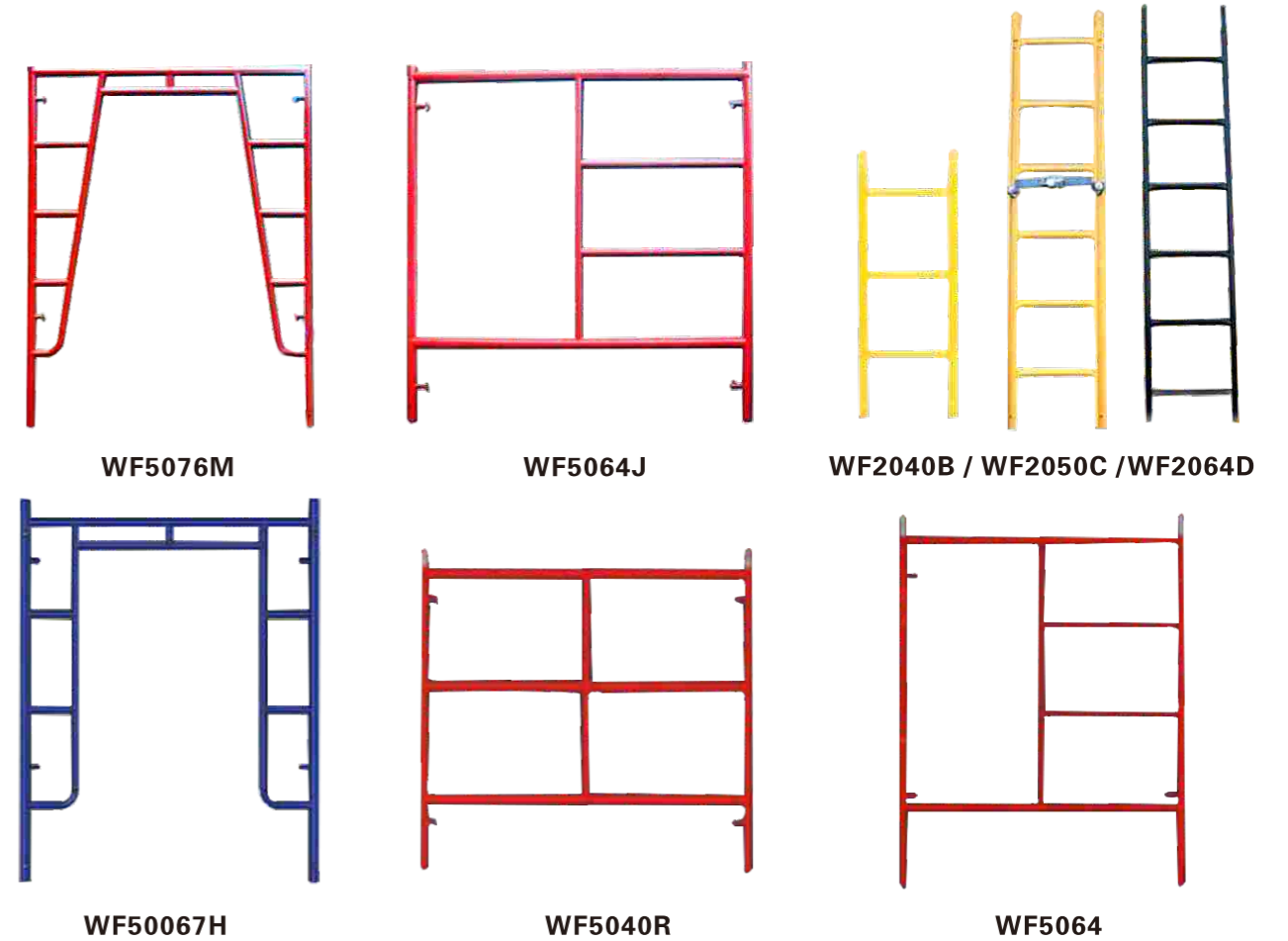

### Finish : Painted , Powder-coated , Hop dip galvanized

Item No.	ERP NO.	Size (W*H)	Weight (lbs)
WF5067H	13115067010	5' x 6'7"	46.7
WF5067W	13135067080	5' x 6'7"	46.7
WF3040K	13113040030	3' x 4'	21.6
WF5068K	13115068010	3' x 6'8"	33.7
WF5050H	13115050010	5' x 5'	37.4
WF5064J	13135064130	5' x 6'4"	44
MF5040R	13145040010	5' x 4'	37.4
MF5050S	13115050010	5' x 5'	41.8
MF2064D	13122064040	2' x 6'4"	30.8
MF2050C	13122050040	2' x 5'	29.5
MF2048B	13122040010	2' x 4'	18.7



## Components

### Scaffold Accessories--Locking Systems

Finish: Zinc plated



Part No.	SA-SR	SA-GP	SA-TP	SA-RP	SA-FHR	SA-SP
Description	Spring Relainer	Gravity Pin	Toggle Pin	Roll Pin	Flat Head Rivet	Snap Pin

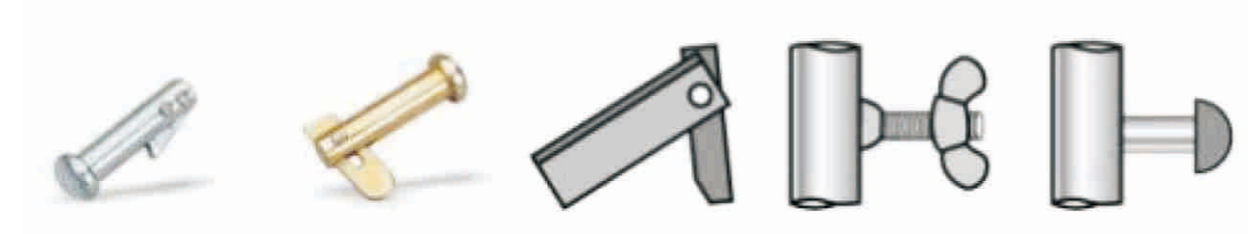

Part No.	SA-DL	SA-FLH	SA-SFL	SA-WN	SA-SOL
Description	Drop Lock	Flip Lock w/Hend	Square Flip lock	Wing Nut	Snap on Lock



Part No.	SA-SLS	SA-SL	SA-FL	SA-TSL
Description	Slide Lock w/2 Slides	Slide Lock w/1 Slides	Fast Lock	Top Slide Lock

### Finish: Hot Dip Galvanizes, Painted

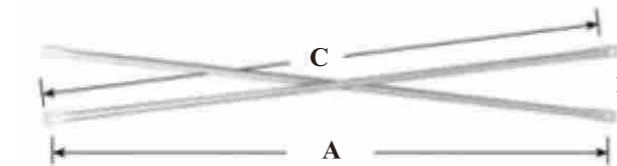

Tubular Cross Brace W/O Flags  
Tube:  $\phi$  25.4 x 61.8mm

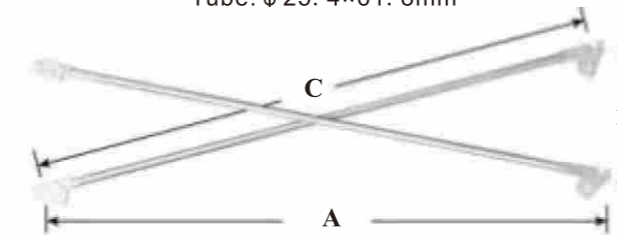

Tubular Cross Brace W/ Flags  
Tube:  $\phi$  25.4 x 61.8mm

### Tubular Cross Brace W/O Flags

ERP No.	Part No.	A	B	C	Weigh(lbs)
13855020030	C1352A	5'	2'	5'4.62"	7.9
13857020020	C1372A	7'	2'	7'3.37"	9.9
13858020030	C1382A	8'	2'	8'2.93"	11
13850020030	C13102A	10'	2'	10'2.37"	14.3
13855040020	C1352A	5'	3'	5'10"	8.8
13857040020	C1373A	7'	3'	7'2.37"	10.6
13858040020	C1383A	8'	3'	8'6.5"	12.6
13850040020	C13103A	10'	3'	10'5.25"	14.9
13855040020	C1354A	5'	4'	6'4.810"	9.5
13857040020	C1374A	7'	4'	8'0.75"	11.7
13858040020	C1384A	8'	4'	8'11.31"	13.2
13850040020	C13104A	10'	4'	10'9.25"	15.4

### Angular Cross Brace

ERP No.	Part No.	A	B1	B2	C	Weigh(lbs)
13855040030	C13543L	5'	3'	4'	5'4.62"	11.5
13857040030	C13743L	7'	3'	4'	7'3.37"	14.96
13858040030	C13843L	8'	3'	4'	8'2.93"	15.9
13850040030	C131043L	10'	3'	4'	10'2.37"	18.9

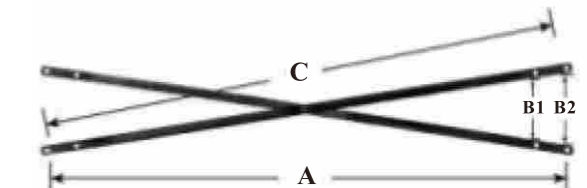

Angular Cross Brace  
Material: 1-1/4" x 1-1/4" x 61/8"

### A-Frame Spacing

### B-Stub Spacing

### C-Center-to-Center Holes

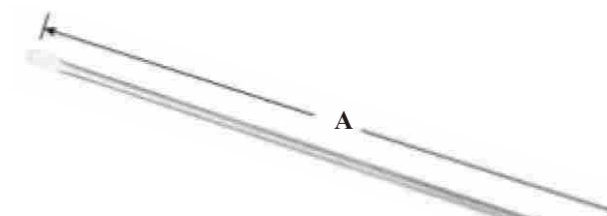

Guard Rail Without Flags

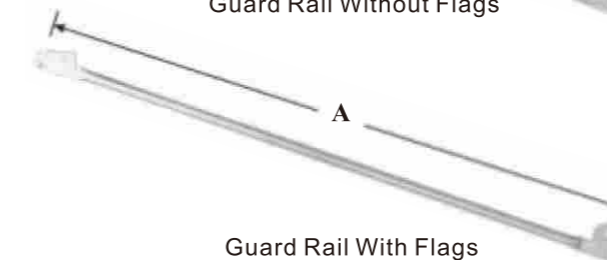

Guard Rail With Flags

### Guard Rail W/O Flags

ERP No.	Part No.	Specification	Weigh(lbs)
13860030030	GR3A	3'	2.2
13860040060	GR4A	4'	3
13860050030	GR5A	5'	3.5
13860070030	GR6A	6'	4.4
13860070030	GR7A	7'	5
13860080040	GR8A	8'	5.8
13860090010	GR9A	9'	6.4
13860010020	GR10A	10'	7.1

## Folding Scaffold

Pro-Shore Folding Scaffold is light weight, simple and quick in assembly and disassembly. Various designs are offered to meet your specific requirements, especially perfect for internal and external decoration and maintenance in houses or hotels.

## Advantages

- Tested Safety
- Light Weight
- Easy to handle
- Convenient to transportation and store
- Durable, Maintenance Free



## X Type Folding Scaffold Aluminum



**4ft Aluminum X Type Folding Scaffold**

ERP #: 14220400010  
 Material: Aluminum 6061-T6  
 Size(mm): 3.8'x1'9"x4'  
 Weight: 36lbs  
 Safe Working Load: 330lbs



**4ft Aluminum X Type Folding Scaffold w/ single side wheels**

ERP #: 14240400020  
 Material: Aluminum 6061-T6  
 Size(mm): 3.8'x1'9"x4'  
 Weight: 32lbs  
 Safe Working Load: 330lbs



**5ft Aluminum X Type Folding Scaffold**

ERP #: 14220500030  
 Material: Aluminum 6061-T6  
 Size(mm): 4'x23.6"x5'  
 Weight: 52.8lbs  
 Safe Working Load: 440lbs



**6ft Aluminum X Type Folding Scaffold**

ERP #: 14220600010  
 Material: Aluminum 6061-T6  
 Size(mm): 4'7"x27.5"x6'  
 Weight: 66.2lbs  
 Safe Working Load: 616lbs

## X Type Folding Scaffold Steel



### 4ft Steel X Type Folding Scaffold

ERP #: 14220400053  
 Material: Steel Q235  
 Size(mm): 3.8'x1'9"x4'  
 Weight: 70.4lbs  
 Safe Working Load: 330lbs



### 4ft Steel X Type Folding Scaffold w/ single side wheels

ERP #: 14220400033  
 Material: Steel Q235  
 Size(mm): 3.8'x1'9"x4'  
 Weight: 72.4lbs  
 Safe Working Load: 330lbs



### 5ft Steel X Type Folding Scaffold

ERP #: 14220500013  
 Material: Steel Q235  
 Size(mm): 4'x23.6"x5'  
 Weight: 56.54lbs  
 Safe Working Load: 440lbs



### 6ft Steel X Type Folding Scaffold

ERP #: 14220600023  
 Material: Steel Q235  
 Size(mm): 4'7"x27.5"x6'  
 Weight: 118.4lbs  
 Safe Working Load: 616lbs

## Multifunctional Scaffold



### Aluminum Multifunctional Scaffold

Guardrail System can be optional subject to your specific working demands.  
 ERP #: 14240600130  
 Material: Aluminum 6061-T6  
 Size(mm): 6'x27.4"x5'5"  
 Weight: 84.5lbs  
 Safe Working Load: 990lbs



### Steel Multifunctional Scaffold

Guardrail System can be optional subject to your specific working demands.  
 ERP #: 14240600633  
 Material: Steel Q235  
 Size(mm): 6'x27.4"x5'5"  
 Weight: 145.4lbs  
 Safe Working Load: 990lbs

## V Type Folding Scaffold



### Aluminum V Type Folding Scaffold w/ Guardrail System

ERP #: 14230600030  
 Material: Aluminum 6061-T6  
 Size(mm): 4'7"x26.7"x9'4.3"  
 Weight: 109lbs  
 Safe Working Load: 330lbs



### Aluminum V Type Folding Scaffold w/o Guardrail System

ERP #: 14230600080  
 Material: Aluminum 6061-T6  
 Size(mm): 4'7"x26.7"x7'  
 Weight: 58lbs  
 Safe Working Load: 330lbs

**Z Type Folding Scaffold**

**Aluminum Z Type Folding Scaffold w/Guardrail System**



ERP #: 14230600110  
 Material: Aluminum 6061-T6  
 Size ( mm ) : 6'3"x26.7"x9'3.4"  
 Weight: 104lbs  
 Safe Working Load: 330lbs



**Aluminum Z Type Folding Scaffold w/o Guardrail System**

ERP #: 14230600160  
 Material: Aluminum 6061-T6  
 Size(mm): 6'3"x26.7"x5'11"  
 Weight: 81.2lbs  
 Safe Working Load: 330lbs



**The Flexi Foldable Scaffolding(AS/NZS 1576.3:1995)**

**Aluminum Easy Folding Scaffold**

ERP#: 19002250030  
 Material: Aluminum 6061-T6  
 Size(mm): 6'3"x26.7"x9'7"  
 Weight: 136.4lbs  
 Safe Working Load: 495lbs

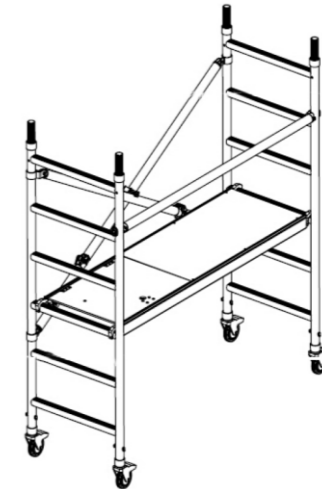

**Base Unit**  
 Width: 26.7"  
 Length: 6'3"  
 Height: 6'10"

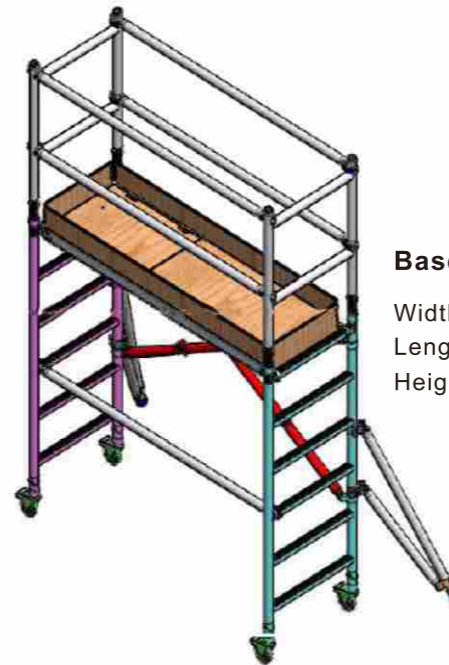

**Base Unit With Guardrail**

Width: 26.7"  
 Length: 6'3"  
 Height: 9'7"

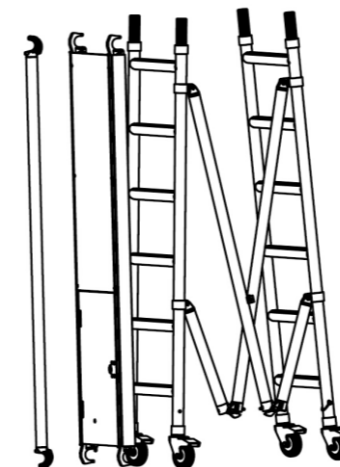

Width: 26.7"  
 Length: 6'3"  
 Height: 15'5"



## Scaffolding Plank

A large variety of Scaffolding Planks are manufactured to suit different market requirements.

### Aluminum Plank



ERP NO.	Size	Weight (lbs)
13925017010	5'x19"	23.1
13927017010	7'x19"	30.8
13928017010	8'x19"	35.2
13920017010	10'x19"	41.8
13927121010	7'x28"	43.6

### Aluminum/Plywood Plank



ERP NO.	Size	Weight (lbs)
13947017060	7'x19"	33
13948017010	8'x19"	39.6
13940017010	10'x19"	48.4

### Aluminum Folding Ramp



ERP NO.	Size	Weight (lbs)
13928000025	7'11.4"x9.5"	33

### Steel Plank



ERP NO.	Size	Weight (lbs)
13932409039	9.4"x2'12"	33
13932424029	9.4"x7'12"	35.2
13932430029	9.4"x10'	44

### Aluminum Plank

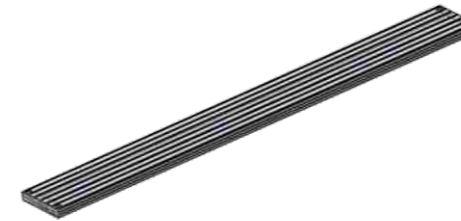

ERP NO.	Size	Weight (lbs)
13920131010	13'1.5"x11"	35.2
13920199010	10'x11"	26.4
13920182010	8'2.5"x11"	22

### Aluminum Trapdoor Plank w/ ladder

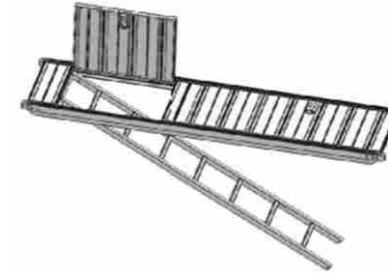

ERP NO.	Size	Weight (lbs)
13928220010	8'2.5"x23.6"	55
13929020010	9'10"x23.6"	63.2

### Trapdoor Plank

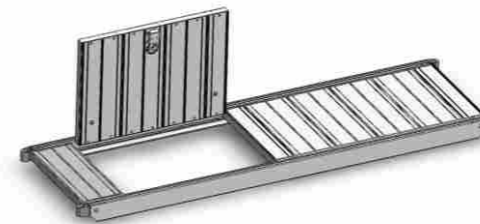

ERP NO.	Size	Weight (lbs)
13941961020	6'6.7"x23.6"	37.4

### Trapdoor Plank w/ ladder

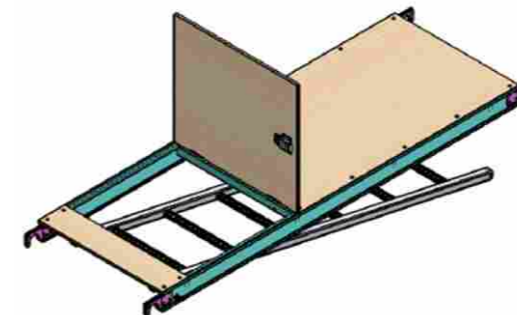

ERP NO.	Size	Weight (lbs)
13940021010	24.8"x9'8"	62.3
13948221010	24.8"x8'	55.7